

Throttle check valve

Type Z2FS

RE 27526

Edition: 2015-01

Replaces: 04.08



- ▶ Size 16
- ▶ Component series 3X
- ▶ Maximum operating pressure 350 bar [5076 psi]
- ▶ Maximum flow 250 l/min [66 US gpm]

Features

- ▶ Sandwich plate valve
- ▶ Porting pattern according to ISO 7/7/4401-0-05 and NFPA T3.5.1 R2-D05
- ▶ Flow limitation of 2 actuator ports
- ▶ Adjustment type: Spindle with internal hexagon
- ▶ Supply or discharge throttling

Content

| | |
|-----------------------|---|
| Features | 1 |
| Ordering codes | 2 |
| Symbol | 3 |
| Function, section | 4 |
| Technical data | 5 |
| Characteristic curves | 6 |
| Dimensions | 7 |
| Further information | 8 |

Ordering codes

| | | | | | | | | | | |
|----------|----------|-----------|-----------|----|----------|----------|-----------|----------|----|----------|
| 01 | 02 | 03 | 04 | 05 | 06 | 07 | 08 | 09 | 10 | 11 |
| Z | 2 | FS | 16 | | 8 | - | 3X | / | | * |

| | | |
|----|----------------------|----------|
| 01 | Sandwich plate valve | Z |
|----|----------------------|----------|

Number of functions

| | | |
|----|--------------------------------------|----------|
| 02 | 2 (throttling in channel A and/or B) | 2 |
|----|--------------------------------------|----------|

| | | |
|----|----------------------|-----------|
| 03 | Throttle check valve | FS |
|----|----------------------|-----------|

| | | |
|----|---------|-----------|
| 04 | Size 16 | 16 |
|----|---------|-----------|

Functions in

| | | |
|----|-----------------|----------|
| 05 | Channel A | A |
| | Channel B | B |
| | Channel A and B | - |

Adjustment type

| | | |
|----|-------------------------------|----------|
| 06 | Spindle with internal hexagon | 8 |
|----|-------------------------------|----------|

| | | |
|----|--|-----------|
| 07 | Component series 30 ... 39 (30 ... 39: unchanged installation and connection dimensions) | 3X |
|----|--|-----------|

Supply throttling/discharge throttling

| | | |
|----|--|-----------|
| 08 | Supply throttling on side A ("...A8-3X/S") | S |
| | Supply throttling on side B ("...B8-3X/S") | |
| | Supply throttling on side A and B ("...-8-3X/S") | |
| | Discharge throttling on side A ("...A8-3X/S2") | S2 |
| | Discharge throttling on side B ("...B8-3X/S2") | |
| | Discharge throttling on side A and B ("...-8-3X/S2") | |

Corrosion resistance (outside)

| | | |
|----|--|----------------|
| 09 | None (valve housing primed) (standard) | no code |
| | Improved corrosion protection (240 h salt spray test according to EN ISO 9227) | J3 |

Seal material

| | | |
|----|--|----------------|
| 10 | NBR seals | no code |
| | FKM seals | V |
| | Observe compatibility of seals with hydraulic fluid used! (Other seals on request) | |
| 11 | Further details in plain text | * |

 **Notice:** Preferred types and standard devices are contained in the EPS (standard price list).

Symbols (① = component side, ② = plate side)

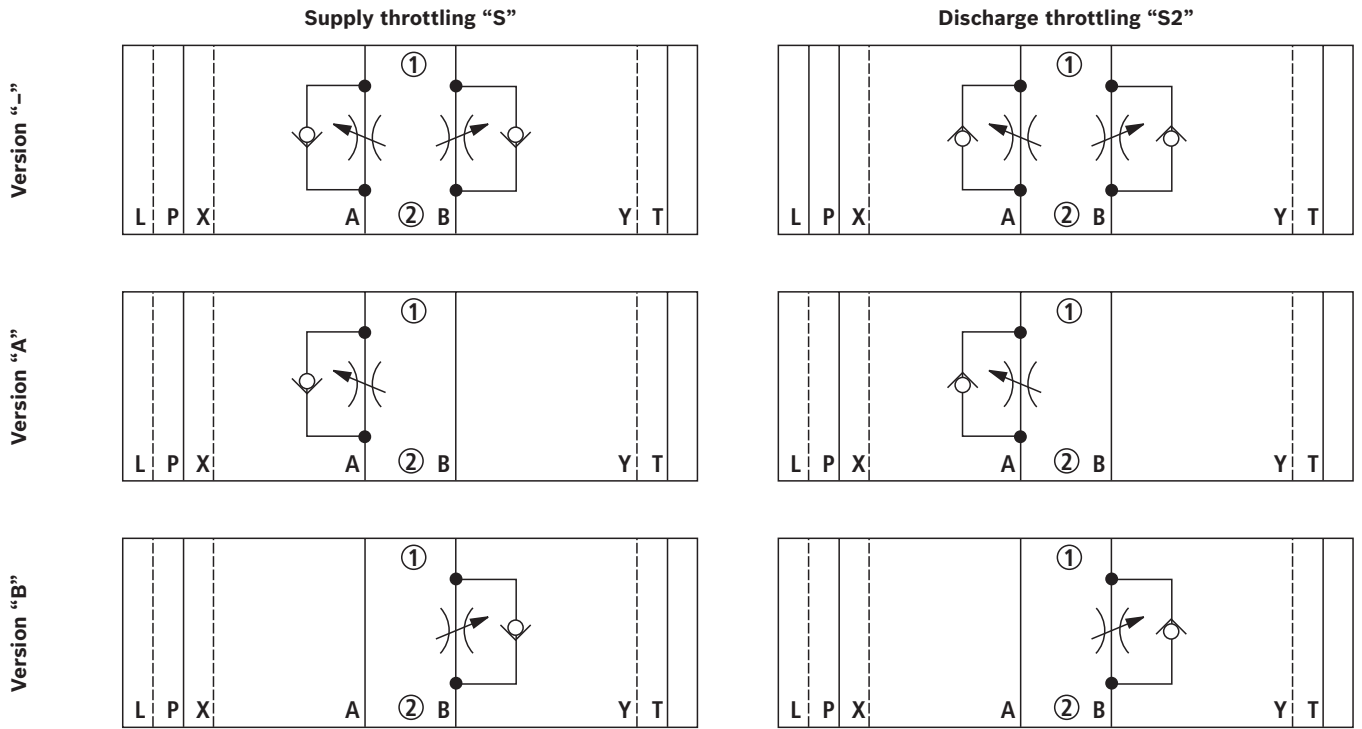

Function, section

The Z2FS-type valve is a throttle check valve in sandwich plate design. It is used to limit the flow of one or two actuator ports.

Two throttle check valves aligned symmetrically to each other limit the flow in one direction (using an adjustable throttle spool) and allow free return flow in the opposite direction.

During supply throttling, the hydraulic fluid arrives at actuator A^② via channel A^① via the throttling point (1). The throttle spool (2.1) can be adjusted axially via the spindle (3), thus enabling the throttling point to be set (1).

Simultaneously, the hydraulic fluid that is present in channel A^① reaches the piston side (5) via the bore (4). In addition to the spring force, the applied pressure holds the throttle spool (2.1) in throttle position.

The hydraulic fluid flowing back from actuator B^② displaces throttle spool (2.2), thus enabling unhindered flow as a check valve. Depending on the version ("S" or "S2"), the throttle effect can occur in the supply or in the discharge.

Flow limitation

For changing the speed of an actuator, throttle check valve is installed between the directional valve and the subplate.

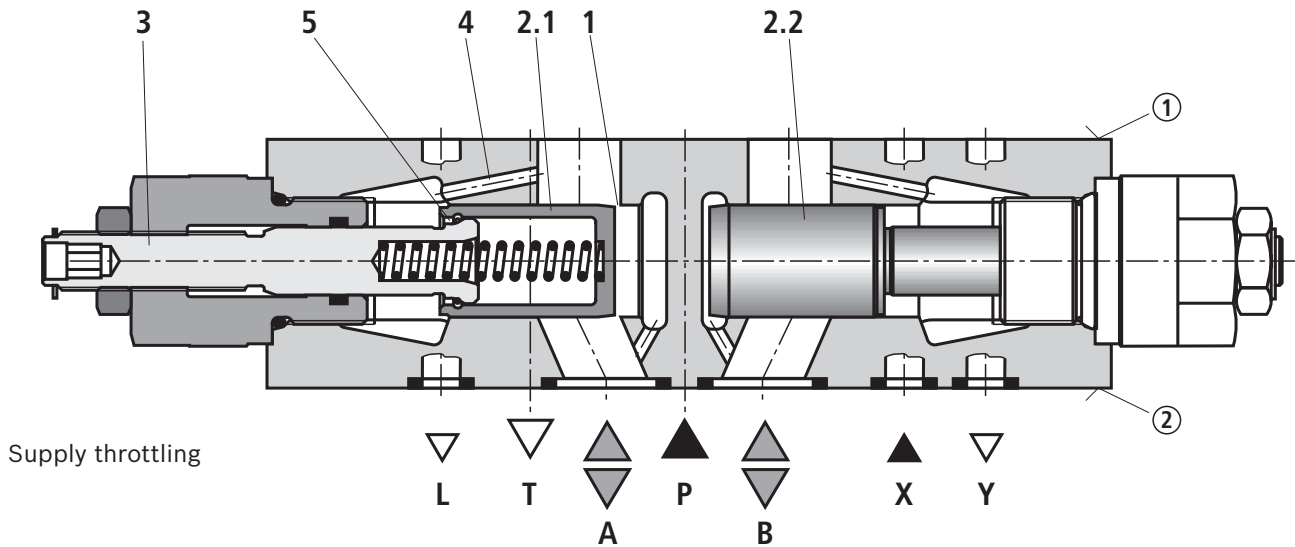

① = component side
② = plate side

Technical data

(For applications outside these values, please consult us!)

| General | | |
|---------------------------|----------|---|
| Weight | kg [lbs] | Approx. 4.7 [10.4] |
| Installation position | | Any |
| Ambient temperature range | °C [°F] | -30 ... +80 [-22 ... +176] (NBR seals) -20 ... +80 [-4 ... +176] (FKM seals) |

| Hydraulic | | |
|---|--------------------------|---|
| Maximum operating pressure | bar [psi] | 350 [5076] |
| Maximum flow | l/min [US gpm] | 250 [66] |
| Hydraulic fluid | | See table below |
| Hydraulic fluid temperature range | °C [°F] | -30 ... +80 [-22 ... +176] (NBR seals) -20 ... +80 [-4 ... +176] (FKM seals) |
| Viscosity range | mm ² /s [SUS] | 2,8 ... 380 [13 ... 1760] |
| Maximum permissible degree of contamination of the hydraulic fluid, cleanliness class according to ISO 4406 (c) | | Class 20/18/15 ¹⁾ |

| Hydraulic fluid | Classification | Suitable sealing materials | Standards | Data sheet | |
|-----------------|----------------------|---|-----------|------------|------------|
| Mineral oils | HL, HLP | NBR, FKM | DIN 51524 | 90220 | |
| Bio-degradable | ▶ Insoluble in water | HEES ²⁾ | ISO 15380 | 90221 | |
| | ▶ Soluble in water | HEPG ²⁾ | ISO 15380 | | |
| Flame-resistant | ▶ Containing water | HFC (Fuchs Hydrotherm 46M, Petrofer Ultra Safe 620) ²⁾ | NBR | ISO 12922 | on request |



Important information on hydraulic fluids:

- ▶ For more information and data about the use of other hydraulic fluids, refer to data sheets above or contact us!
- ▶ There may be limitations regarding the technical valve data (temperature, pressure range, life cycle, maintenance intervals, etc.)!
- ▶ The flash point of the hydraulic fluid used must be 40 K higher than the maximum solenoid surface temperature.

▶ Flame-resistant – containing water:

- Maximum pressure differential 210 bar, otherwise, increased cavitation
- Pressure pre-loading at the tank port > 20% of the pressure differential, otherwise increased cavitation
- Life cycle as compared to operation with mineral oil HL, HLP 30 to 100%

Characteristic curves

(measured with HLP46, $\vartheta_{Oil} = 40 \pm 5 \text{ }^\circ\text{C}$ [$104 \pm 9 \text{ }^\circ\text{F}$])

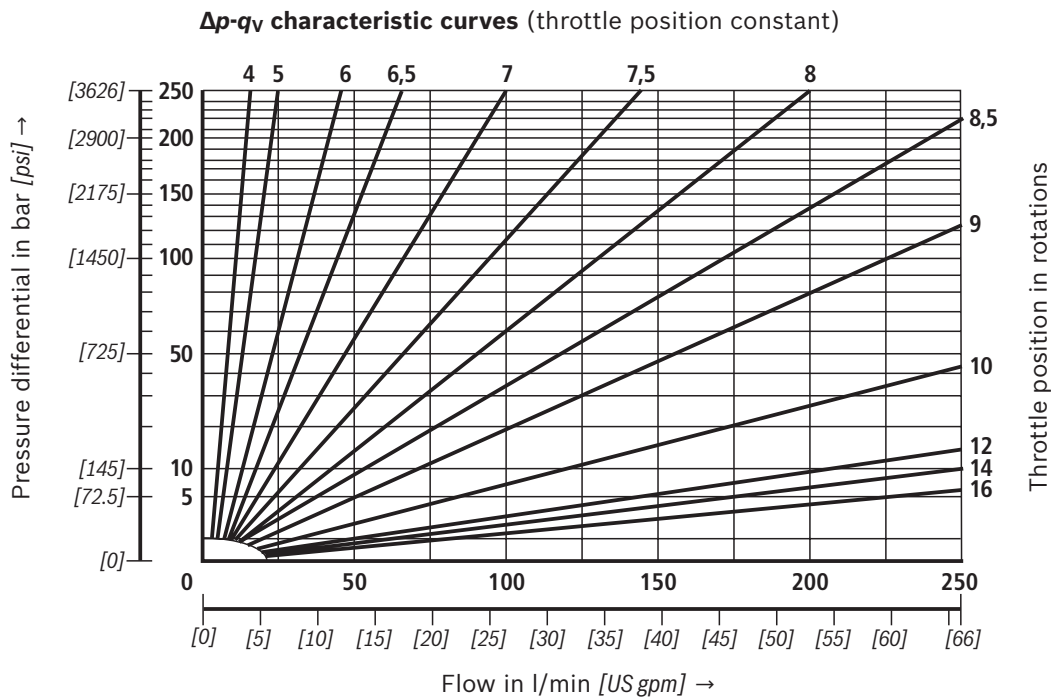
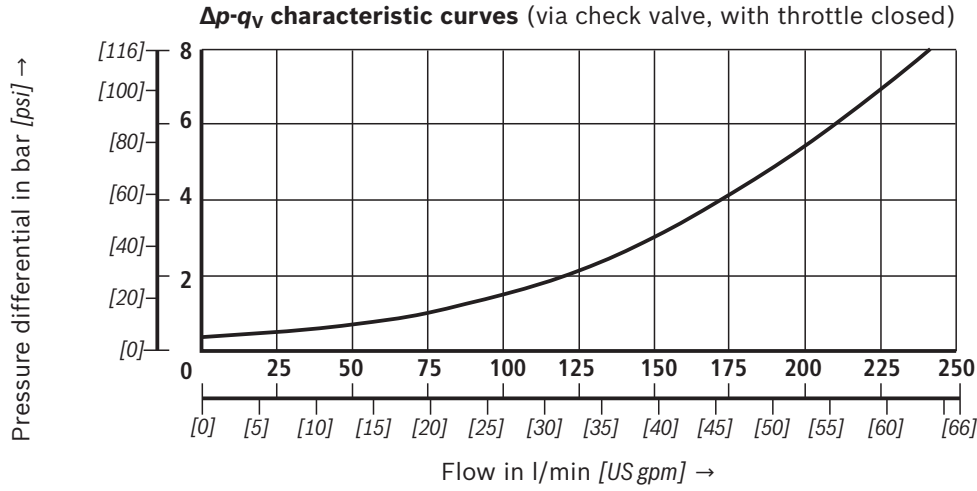

Dimensions

(in mm [inch])

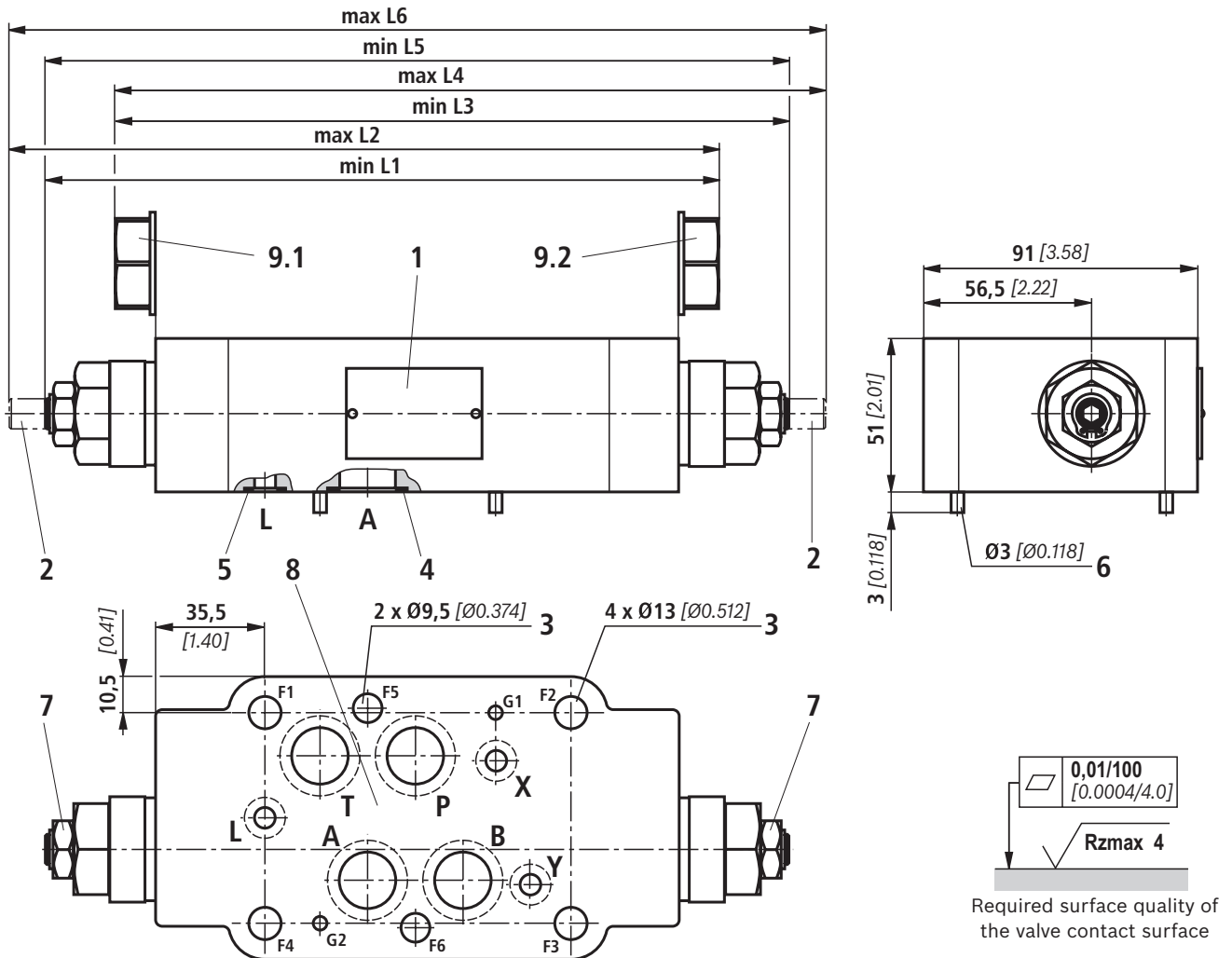

| "Corrosion resistance" version | L1 | L2 | L3 | L4 | L5 | L6 | Pos. 7 M_A in Nm [ft-lbs] ±10 % |
|--------------------------------|------------|------------|------------|------------|------------|-------------|---|
| "no code" | 224 [8.82] | 248 [9.76] | 224 [8.82] | 248 [9.76] | 246 [9.68] | 294 [11.57] | 25 [18.4] |
| "J3" | 227 [8.94] | 251 [9.88] | 227 [8.94] | 251 [9.88] | 252 [9.92] | 300 [11.81] | 33 [24.3] |

- 1 Name plate
- 2 Adjustment type "8"
Spindle for changing the flow cross-section (internal hexagon SW6)
 - ▶ Anti-clockwise rotation = higher flow
 - ▶ Clockwise rotation = smaller flow
- 3 Through holes for valve mounting
- 4 Identical seal rings for ports A, B, P, T
- 5 Identical seal rings for ports X, Y, L
- 6 Locking pin (not included in the scope of delivery)
- 7 Hexagon SW19, tightening torque M_A see table above
- 8 Porting pattern according to ISO 7/7/4401-0-05 and NFPA T3.5.1 R2-D05
- 9.1 Plug screw for version "B"
- 9.2 Plug screw for version "A"

Valve mounting screws (separate order)

- ▶ metric
 - 4 hexagon socket head cap screws ISO 4762 - M10 - 10.9-fIZn-240h-L
 - 2 hexagon socket head cap screws ISO 4762 - M6 - 10.9-fIZn-240h-L
- ▶ UNC
 - 4 hexagon socket head cap screws 3/8-16 UNC
 - 2 hexagon socket head cap screw 1/4-20 UNC

Notice:

Length and tightening torque of the valve mounting screws must be calculated according to the components mounted under and over the sandwich plate valve.